

UNDERWATER EXHAUST HORIZONTAL

PART#	A1	A2	B1	B2	C	D	E1	E2	M
	IN/OUT IN/MM	BYPASS IN/MM	I/O LGTH IN/MM	BP LGTH IN/MM	LGTH IN/MM	DIA IN/MM	I/O ELEV IN/MM	BP ELEV IN/MM	BP OFFSET IN/MM
107H500	5.00 / 127	2.50 / 64	5.00 / 127	3.00 / 76	28 / 711	10.40 / 264	2.16 / 55	2.75 / 70	13.82 / 351
107H600	6.00 / 152	3.00 / 76	6.00 / 152	3.50 / 89	34 / 864	12.34 / 313	2.84 / 72	2.81 / 71	17.00 / 432
107H800	8.00 / 203	4.00 / 102	8.00 / 203	4.50 / 114	45 / 1,143	16.11 / 409	3.72 / 94	3.75 / 95	22.50 / 572
107H100	10.00 / 254	5.00 / 127	8.00 / 203	5.00 / 127	52 / 1,321	18.41 / 468	3.80 / 97	3.81 / 97	26.00 / 660
107H120	12.00 / 305	6.00 / 152	8.00 / 203	6.00 / 152	60 / 1,524	24.60 / 625	5.75 / 146	5.75 / 146	30.00 / 762
107H140	14.00 / 356	6.00 / 152	8.00 / 203	6.00 / 152	66 / 1,676	28.50 / 724	6.75 / 171	6.75 / 171	33.00 / 838
107H160	16.00 / 406	8.00 / 203	10.00 / 254	8.00 / 203	78 / 1,981	28.50 / 724	5.75 / 146	5.75 / 146	39.00 / 991
107H180	18.00 / 457	8.00 / 203	10.00 / 254	8.00 / 203	85 / 2,159	34.00 / 864	7.75 / 197	7.75 / 197	42.50 / 1080

Application: Inboards • Fuel type: Gas/Diesel • Waterline: Above Only • Sound rating: Best

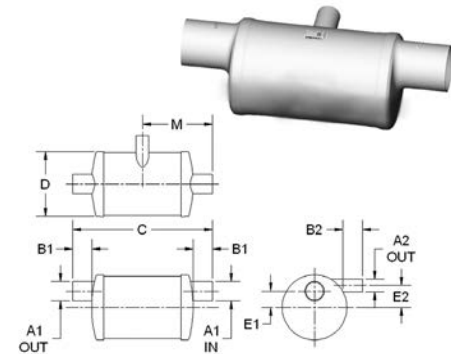

UNDERWATER EXHAUST VERTICAL

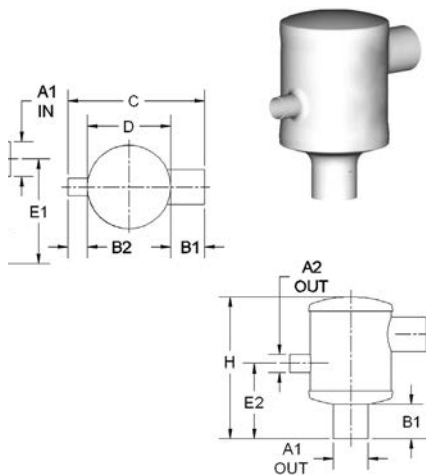

PART#	A1	A2	B1	B2	C	D	E1	E2	H
	IN/OUT IN/MM	BYPASS IN/MM	I/O LGTH IN/MM	BP LGTH IN/MM	LGTH IN/MM	DIA IN/MM	INLET ELEV IN/MM	BP ELEV IN/MM	HGT IN/MM
107V500	5.00 / 127	2.50 / 64	5.00 / 127	3.00 / 76	20.50 / 521	12.50 / 318	16.00 / 406	2.75 / 70	21.00 / 533
107V600	6.00 / 152	3.00 / 76	6.00 / 152	3.50 / 89	24.00 / 610	14.50 / 368	18.00 / 457	2.81 / 71	24.50 / 622
107V800	8.00 / 203	4.00 / 102	8.00 / 203	4.50 / 114	31.00 / 787	18.50 / 470	23.25 / 590	3.75 / 95	31.50 / 800
107V100	10.00 / 254	5.00 / 127	9.00 / 229	5.00 / 127	36.00 / 914	22.00 / 559	27.75 / 705	3.81 / 97	37.50 / 953
107V120	12.00 / 305	6.00 / 152	10.00 / 254	6.00 / 152	40.75 / 1,035	24.75 / 629	33.00 / 838	5.75 / 146	44.50 / 1,130
107V140	14.00 / 356	6.00 / 152	11.00 / 279	6.00 / 152	45.50 / 1,156	28.50 / 724	38.75 / 984	6.75 / 171	50.50 / 1,283
107V160	16.00 / 406	8.00 / 203	12.00 / 305	8.00 / 203	55.00 / 1,397	35.00 / 889	45.63 / 1,159	5.75 / 146	58.00 / 1,473
107V180	18.00 / 457	8.00 / 203	13.00 / 330	8.00 / 203	56.00 / 1,422	35.00 / 889	46.75 / 1,187	7.75 / 197	62.00 / 1,575

Application: Inboards • Fuel type: Gas/Diesel
Waterline: Above Only • Sound rating: Best